

# The tuyere in a protective shell to convert the nickel and copper mattes

**Yu. A. Korol**, Vice President <sup>1</sup>, e-mail: tsvetmet@rudmet.ru

**S. S. Naboychenko**, Visiting Professor at the Department of Non-Ferrous Metals<sup>2</sup>

<sup>1</sup> JSC "Russian Copper Company", Ekaterinburg, Russia.

<sup>2</sup> Ural Federal University Named after the First President of Russia B. N. Yeltsin, Yekaterinburg, Russia.

The wide spread of the process of converting for recycling of copper, copper-nickel and nickel mattes, it determines the relevance of finding ways to improve the design of converters and, especially, the protection of refractory lining.

The reducing of specific costs for receiving the oxygen and getting the high capacity of oxygen plants give more opportunities for recycling of raw material and melting of solid metals in the melt, and this is for its part stimulates the design of converters with long-term companies in an aggressive environment.

The promising direction is the using of the tuyeres in a protective shell from the higher pressure air, inert gas (nitrogen, argon), natural gas or steam-air mixtures. In our country, the realization of this direction in iron industry has started in the middle of the last century after publishing and conducting experimental work by I. P. Bardin, S. G. Afanasiev, M. M. Shumov, Z. D. Epstein and N. I. Mozgovoy. Abroad, the tuyeres in a protective shell at first were implemented by Guy Savard and Robert Lee (Canada).

In nonferrous industry first experimental works were conducted in 80-s for the industry of lead, nickel and copper. Nowadays in China, the processes with the tuyeres are using in more than 40 plants and the Chinese experts infuse this technology (SKS) in new plants under constration. The main distinctive feature of SKS is the implementation of the air and nitrogen in high pressure, what makes it possible to refuse of the using of the mechanisms and devices for cleaning of the tuyeres and also the using of the air blasting, enriched in oxygen. In our country the using of the tuyere in a protective shell (TPS) was first implemented at the plant "Yuzhuralnickel" in the 80-s. The implementation of this equipment on 13 converters allowed to stabilize the work of converter area, increase by several times the campaign of converters and improve their operating conditions.

The feature of TPS at the plant "Yuzhuralnickel" is the applying of the conditions of the air blasting and low pressure protective environment (0.06–0.12MPa) without a fundamental and costly changes in the design of operating converters.

The experience of the applying such construction let to specify the protection mechanism of refractory lining in conditions of aggressive melt of sulphides of non-ferrous metals with oxygen air blasting and using nitrogen, steam, vapor-air and high pressure air as a protective environment.

Conducted research and developed methodology with a mathematical model allowed to create the recommendations for copper-nickel converters, equipped with TPS for practical using in every specific working conditions.

**Key words:** converter, nickel matte, tuyere, tuyere in a protective shell, melt temperature, refractory lining, sullage, matte, natural gas, nitrogen, nickel, cobalt, copper.

**DOI:** 10.17580/nfm.2018.02.01

The wide spread process in the metallurgy of heavy non-ferrous metals is the converting of mattes.

The advantages of this technology: auto-genousness; high speed of metallurgical reactions; opportunity to get metallurgical products any degree of readiness, simplicity of implementation, scalability of equipment.

The disadvantages are: gas dilution; need of high quality staff, frequency of technological operations etc.

For copper-nickel production and especially for recycling of nickel mattes, the main disadvantage of the converting process is considered low life of refractory lining.

For copper converters campaign life between routine repairs composes from 3 to 6 month (it depends on grade of copper concentration in mattes and quantity of digestible waste), compares to nickel converters which campaign life does not exceed 12 days [1–2].

The refractory lining of converter is exposed several factors: chemical (melt interaction with lining), thermic (high temperature and its sudden drops), mechanical (cleaning of tuyere, loading of large materials, junk and raw feedings, hits on converter's body frame during its maintenance), led to its severe wear and as follows to reduce of the campaign.

In this article, the authors will explore the impact of the thermic factors on equipment operating.

Low speed of the air blast in the melt does not let to transfer high-temperature area of flame from lining of the converter that led to severe wear of the wall of the tuyere due to temperature at 1600–1700 °C [3–4].

The main ways to protect lining are created in several trends:

– design and implementation of chock-resistant refractories;

- applying of the protecting covers on the fire delivery part of lining;
- applying of the coolant systems of lining with the use of both overhead and embedded caissons, cooling elements;
- using of the process technology as the reducing the combustion rate on the refractories through the change of blast characteristics, composes of blasting air, time and speed of metallurgical reactions, quantity and quality of the converted “cool” feedings and waste metal;
- design and implementation of the various tuyere devices and ways to use them for conveying of air blasting into converter.

Considering the last trend, we highlight the process technology for protection refractory lining with use of the tuyeres in a protective shell.

In iron industry the design of the tuyere in a protective shell (TPS) for ground air blasting has started to implement since 50–60-s the last century [5–13].

This tuyere allows to use blow gases on the way as well for protection of refractory lining as for solving technological issues on steel refining from harmful traces.

In USSR the design and first semi-industrial tests of the tuyere “pipe-in-pipe” was conducted by I. P. Bardin, S. G. Afanasiev, M. M. Shumov, Z. D. Epstein and N. I. Mozgovoy in 1946 for converting of high-phosphorous iron.

The authors used carbon dioxide in the capacity of protective environment [14–15]. Later the works on the were stopped due to the lack of prospects for the redistribution of phosphorus iron.

Abroad the first implementators in 1964 and patent holders on TPS for getting steel in 1966 were Guy Savard and Robert Lee (Liquid Air company, Canada). After lots of semi-industrial tests in Germany on Thomas converter these design and technology was patented in 1972 named OBMM (Oxygen Bottom Metallurgy Maxhutte) [16].

In nonferrous industry the first mention of the possibility to use TPS was connected with the process, designed and patented by Paul E. Queneau, Reinhardt, Guy Savard and Robert Lee in 1974 that was named (Queneau-Schuhmann Oxygen Process) and later changed to QSL (Queneau-Schuhmann-Lurgi).

Initially, this technology was planned to use for converting of copper matte and scrap material, but later was redirected to convert of lead concentrates with oxygen enrichment.

The practical realisation of the process was carried out in Maxhutte in 1975.

The main distinctive feature of the tuyere, used in these processes, was its complicated mechanical construction, that was propelled by pressure of air, oxygen and protective mixtures from 500 to 1500 kPa (Fig. 1).

The QSL process was implemented in the 90-s at the following enterprises:

- Cominco Trial, with the capacity of 120 000 tonnes;
- Berzelius Stolberg, with the capacity of 80 000 – 155 000 tonnes;

- Bayin, China, with the capacity of 52 000 tonnes;
- Korea Zinc, Onsan, with the capacity of 60 000 – 130 000 tonnes.

In the copper industry the first tests of the TPS were carried out in 1992 at the plant of Union Miniere Hoboken (Belgium).

The tests were considered successful, but despite this, in 1995 the plant was reconstructed under using the process of Isasmelt [17–18].

In nickel industry the first tests were carried out in Canada at the plant Falconbridge in 1999 [18–19].

During the tests the oxygen content in air blasting during processing of copper-nickel mattes was risen up to 30%.

At the same time the resistance of refractories has not changed.

The Canadians gave the proper name to this technology – ALSI Technology, and the converter with these tuyeres called SMC (Slag-Make Converting).

During the period 1999–2006 on this reactor were made the following improvements:

- the level of the oxygen enrichment rose up from 30 to 40%;
- the quantity of the tuyeres eased from 13 to 9;
- the size of annular gap was diminished on 35%.
- the deep of the tuyere dipping in melt was increased;
- the materials-handling system and gas removal system were changed [20–22].

The further development of converting technology on the base of the Guy Savard and Robert Lee patent went to China, where the main process was called SKS.

In 1999 in this country was built the plant Shuikoushan for the proposes of lead concentrates converting.

Nowadays the Chinese companies have been realized more than 40 projects based on this technology [23]. The technology of converting copper materials using SKS equipment was implemented in 2001. One of the first plants based on SKS technology for processing of copper concentrates is the enterprise in Vietnam put into operation in 2008. [24–26].

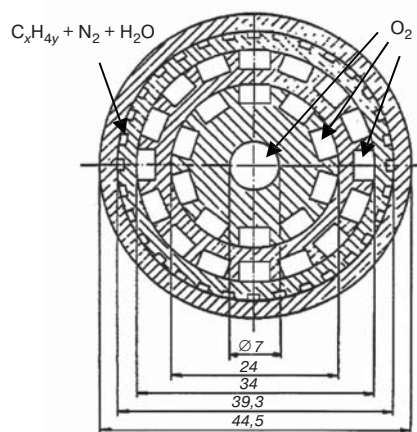

Fig. 1. Cross section of the tuyere process QSL [16]

The main characteristic feature of TPS used abroad (patents by Paul E. Queneau, Reinhardt, Guy Savard and Robert Lee) is the use of air blasting at the level of 500–1500 kPa, the rather complicated design of the tuyere and fan drift, the lack of constructive possibility of cleaning tuyeres from internal and external scars.

In Russia the first mention about possibility to process copper-nickel ores with the use of oxygen blasting dipped in a melt and with nitrogen as a protective shell was proposed by Tsemekhman L. Sh., Ezhovy E. I. and Pevzner M. I. in 1972. [27].

In 1980, a team of authors from the Gipronickel Institute published a theoretical methodology and basic principles for calculating a tuyere in a protective shell with research results on an experimental unit for smelting copper-nickel sulfide raw materials. [28].

The theoretical reason and the design of TPS construction for application on 30 tonnes converters for processing of nickel mattes at the concern “Yuzhuralnickel” was made by Korol Yu. A. in 1983. Later, the design of the tuyere part was modified for practical using on converter, bypassing the stage of laboratory and pilot tests.

In 1987–1988 in the melting shop of “Yuzhuralnickel” such TPS systems were implemented on 3 of 13 converters and later by the end of 1989 this system was carried out on all converters.

The active part for implementation of TPS was held by Trukhankin A. V., Pichugin V. V., Denisov V. N and Pashkovskiy A. A.

In the initial period, in the function of protective shell were used gaseous nitrogen or compressor air or converter blow air. In 1989 with the participation of specialists from the design institute Gipronikel (Barsukov N. M., Rusakov M. R. and Galnbek A. A.), the design was modified with the possibility of using natural gas or a vapor-water-fuel oil mixture as a protective environment. In 1990 TPS installation with protective environment of natural gas was launched at the converter of depletion converting slags № 7 [29].

The main propose for using TPS on nickel converters was in increasing the campaign of converters by extending service life of the lining of tuyere belt.

The idea of “wrapping” the blast flame at the exit of the tuyere nozzle into the melt with an inert gas (nitrogen), or a gas that lowers the temperature of the melt in the area of the tuyeres due to endothermic reactions of its decomposition (natural gas, steam-water-oil mixture) was borrowed from the experience of using TPS in ferrous industry. [5].

As the result of this target and the restrictions in the use of high-pressure blasting, the new design of tuyere in a protective shell, using a blast of low (up to 100 kPa) energy parameters, appeared (Fig. 2).

TPS is represented “pipe(5)-in-pipe(6)” fixed in the distributing device of the tuyere collector (4) by screwing them in with a gap between the walls of the pipes from 1 to 2 mm. Protective gas is supplied to the distribution device of each tuyere from the corresponding collector (1).

The air blasting came from air collector (2). The control (tuyering, cleaning) of the condition of air tuyere is carried out through air shutter (3).

The tuyere works in the following manner: converter air under pressure of 90–100 kPa is feeding into the main collector and is blowing through the distributing device and through the inner tube into the converter melt; the protective gas is flowing through the gas collector and is blowing through the distributing device into the gap between the inner wall of the outer pipe and the outer wall of the inner pipe; at the end of this process from the gap the protective gas is wrapping the air flame, preventing it from reacting with the melt directly near the tuyere belt, thereby protecting the lining from high temperatures.

In the specialized literature, a very small number of works is devoted to the calculation of tuyeres in a protective shell with low blowing parameters for the main carrier of oxygen and the protective environment of the air, nitrogen, natural gas or vapor-air mixture.

Thereby, the authors of this article has developed and proposed their own method of calculation of tuyeres with a protective shell for low pressure blasting and created a mathematical model on the basis of a table editor Excel [30]. The basis of these calculations is the main message that to ensure the closure of the air flame with protective gas environment, it is necessary to prevent their mixing on the tuyere slice. To ensure this condition, the speed of air and gas flow from the tuyere in the melt of the converter must be the same.

During the operation of the tuyeres in a protective shell, several options with different inner diameters were tested which were limited by the sizes of the tuyere channel in the refractory brick [30]. Summary characteristics of one of the options for converter of 30 tonnes are shown in the Table 1.

The practical results of the design calculation and the implementation of tuyeres with protective shells on nickel converters were confirmed together with the research on a cold lab bench conducted by the staff of the Gipronickel Institute in 1987–1990. A. Galnbek,

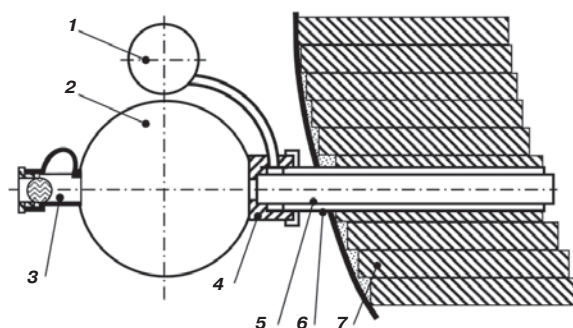

Fig. 2. The design of the tuyere in the protective shell: 1 – collector of the protective gas (natural gas, nitrogen, vapor-water-fuel mixture, compressor air, converter air); 2 – collector of the air blasting; 3 – air shutter; 4 – distributing device; 5 – inner tuyere; 6 – outer tuyere; 7 – lining of tuyere belt of converter

A. N. Barsukov, M. R. Rusakov, E. I. Ezhov and Nedvetsky E. P. [31].

The studies have shown that, with the presence of a protective shell, the level of turbulent pulsations sharply decreases, the flow retains its sizes at 1.5–3 of the diameter of the main channel and the flare opening is observed far from the wall. The penetrating ability of the air flow increases with the use of TPS and the greatest effect is achieved at flow rates of 250 m/s.

With the speed below 100–150 m/s, the effect of using TPS on a cold model is not observed. During testing, of TPS the researchers found out a significant effect of damping torch pulsations, bath oscillations and a decrease in wave formation on the surface of the liquid.

The experiments of Gipronikel’s employees on a hot model using a single tuyere on nickel and copper-nickel mattes fully confirmed the data previous obtained to on a cold model and working converters of the “Yuzhuralnickel” concern. In addition, the analysis of heat loads on the refractory lining allowed in 1990 to recommend the use of oxygen-enriched blasting on copper, nickel and copper-nickel converters equipped with tuyeres in a protective shell. [32].

The technological scheme of the converter redistribution of the plant is shown in Fig. 3. Its distinctive feature

is the use of the method of mixing liquid molten phases of slag, matte and mass for depletion of converter slags [33].

The core of this method is to fill the converter, heated by natural gas, with two or three buckets of matte, overflowing one of the converter slag into it, the blowing in within 0.5–2.0 minutes with air and the following slag sediment above the matte. After 5–10 minutes of sediment, the slag is poured into the ladle and is dumped. As the portions of slag are processed, the mass of the melt is enriched with nickel and cobalt and is depleted in iron.

The control over the content of non-ferrous metals in waste slag in practice is carried out through regular analysis of the melt mass for the content of cobalt. After reaching the cobalt content in the mass of 1.3%, the processed slags become reusable and depleted in the same way in the secondary depletion converter. The mass in the primary depletion converter is reduced to 4–6% by cobalt and, after complete slag discharge, is transferred into the autoclave melting converter.

The mass of the secondary depletion converters is going for further processing either into the converter of the autoclave mass smelting or into the collecting converter, depending on the tasks to balance the nickel between autoclave mass and converter matte. The type composition of the refinement products during the depletion of the converter slag by the method of phase mixing is presented in Table 2.

The practice of using tuyeres in a protective shell of nitrogen in the processing of nickel mattes showed an increase in the campaign of converters the set in 2.5 times (from 5–8 days to 16–34). The campaign of depletion converters increased in 1.5–2 times (from 50 to 90 days). Converter of preparation and melting of autoclave mass increased the operating time from 13–15 days to 22–29 days. The campaign of depletion converters increased by a smaller amount due to their periodic overflow with slag and a decrease in speed of air blasting below 100–120 m/s. Under these conditions, the effect of TPS at the

Table 1

Comparison of TPS options

Indicators	Calculation	Actual data
Internal diameter of the air tuyere, mm	40	40
Outer diameter of the air tuyere, mm	48	48
Internal diameter of the nitrogen tuyere, mm	52	52
Outer diameter of the nitrogen tuyere, mm	60	60
Width of the gap, mm	2	2
Air consumption on the tuyre, m <sup>3</sup> /hr	1311	1100–1400*
Nitrogen consumption on the tuyre, m <sup>3</sup> /hr	320	200–260*

\*Actual cost fluctuations are associated with changes in the level of the melt above the tuyeres and its density during the conversion process

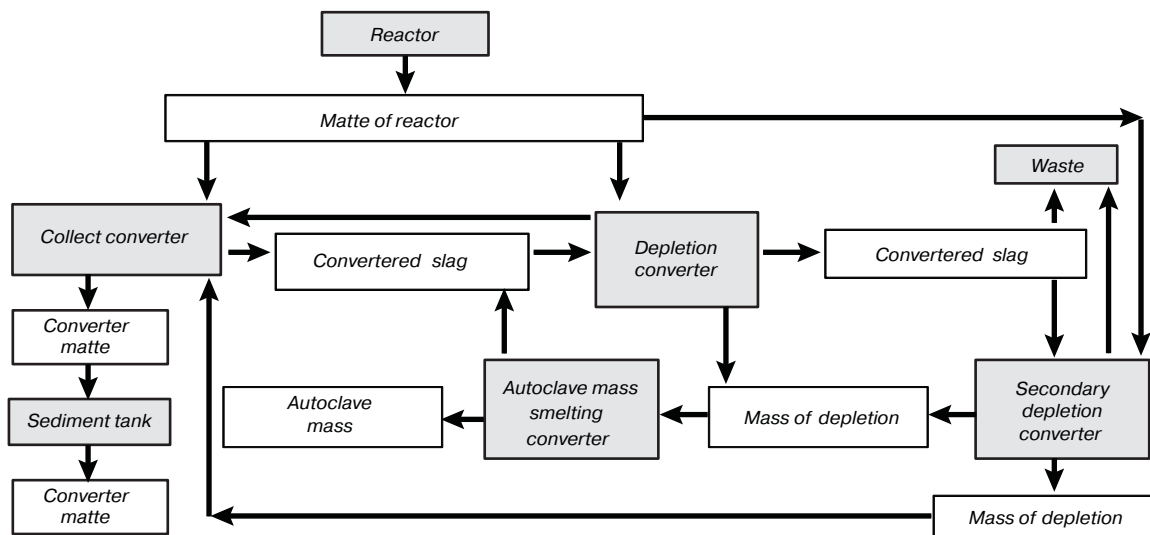

Fig. 3. Scheme of nickel matte processing and converter slag depletion

applied air and nitrogen parameters was practically not observed [32–34]. The main reason for their stop was caused by the burning of tuyeres in refractory bricks (Fig. 4). In this case, the flame was centered in the tuyere area and the tuyere tube itself was exposed to heat, the lining remained intact. This problem was solved by working with the TPS, where natural gas was used as a protective gas.

The results of TPS testing with a protective environment in the form of natural gas in converters for the depletion of converter slag using the method of mixing liquid phases made it possible to determine two technological effects:

- the first one – increasing the depletion converter campaign from 50 days on a standard blasting to 105 days (Fig. 5) using TPS with natural gas due to more smooth wear of the refractory lining and reducing the possibility of tuyere burning out, making “holes” in refractory with decomposing natural gas at the slice of the tuyere and with heat absorption;

- the second one – reduction of free oxygen in the blasting and burning of natural gas conversion products, reduces the partial pressure of oxygen in the melt, reduces the degree of oxidation of metallic and sulfide iron matte thereby increasing the efficiency of depletion operation by the method of phase mixing.

An additional effect on the depletion of slags in the conditions under consideration was observed only for cobalt and nickel. The decrease copper content in nickel slag was not recorded due to its low content and other mechanism of copper distribution between mass and slag. A high share (more than 90%) of the content of dissolved sulfide copper and its mechanical losses makes the extraction of copper from slags effective only by good mixing, following sediment, viscosity reduction of the slag and temperature rise.

Examining the results of the research, the authors clarified the mechanism of the impact of the blasting on the bath of the converter, expressed in a number of publications by B. N. Zakharov, V. A. Vorobyov, I. F. Khudyakov, A. A. Babajan, A. A. Galnbekom, A. I. Tikhonov, V. I. Smirnov, A. A., Zeidler, L. M. Shalygin, J. P. Kapusta, A. A. Bustos, B. R. Macnamara etc.

The core of this mechanism is the penetration of the air blow into the melt (Area 1, Fig. 6) to a depth (range) determined by the blasting pressure, the melt level and its specific gravity. The higher the melt level (Converter overflow), the higher the density of the melt as it is purged by air and iron removal, the smaller penetration of the blasting into the bath, the more flame is pressed against the tuyere belt, creating a high temperature zone in this area and high circulation of the melt in the counterflow with the air movement.

Melt flow in this Area 3 (Fig. 6) is directed down along the wall and destroys the lining of the converter by additional strain and penetration of superheated and liquid melt behind the

tuyere zone of the brick through cracks and chips in the lining. This flow does not allow to set a protective slag lining on the surface of the brick.

The second significant area of the melt circulation (Area 2, Fig. 6) moves along the bottom of the converter downwards and washes the tuyere zone by an ascending flow from below. This area may have several additional circulations caused by and determined by the level of the melt, the angle of inclination of the tuyeres, the position of the converter, the presence of waste and cold additives in the converter.

Table 2

Type composition of melts and refinement products, %

	Ni	Co	Fe
Matte room	15–17	0.1–0.2	55–60
Converted slag	1.2–7.5	0.1–0.6	42–50
Converter matte	76–78	0.3–0.4	0.6–0.8
Mass of the depletion converter	20–30	1.3–6.0	40–45
Mass of the secondary depletion converter	18–20	0.9–1.3	45–50
Return slag	0.2–0.6	0.06–0.90	44–50
Waste slag	0.13–0.15	0.05–0.06	44–52
Converter matte after sediment tank	77–78	0.3–0.4	0.2–0.3

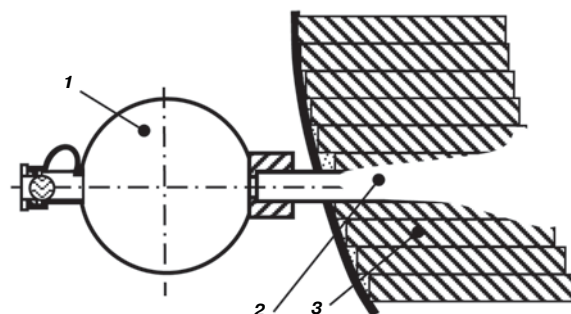

Fig. 4. The tuyere of the depletion converter without TPS:  
1 – tuyere collector; 2 – burnout in the lining of the tuyere belt;  
3 – refractory lining

Lining thickness, mm

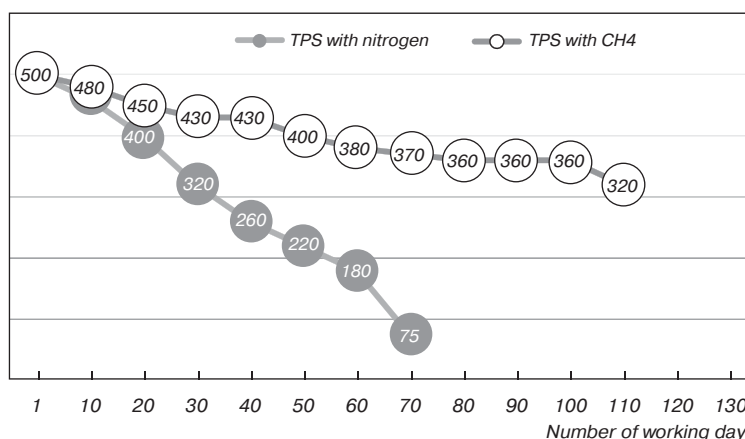

Fig. 5. Thickness variation of the lining of the tuyere belt with TPS of nitrogen and CH<sub>4</sub>

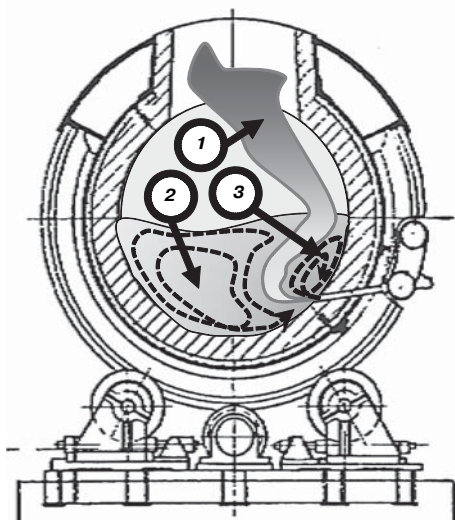

Fig. 6. The mechanism of the impact of the blasting on the melt:

As the result, in the tuyere area there are two opposite flows of the melt and a blasting flame, which creates a temperature on the level of 1200–1700 °C. Mechanical, thermal and chemical effects of aggressive melt significantly limit the service life of refractories with no protective slag lining.

If using a protective shell, there is an additional phenomenon associated with the “wrapping” of blast air into the shell of neutral gas, which prevents the interaction of the oxygen of the blasting with the melt at a distance of 3–4 diameters from the wall of air tuyere. This distance depends on the gas velocity of the protective shell and its pressure at the tuyere cut.

The higher the speed and pressure, the further the flame “breaks through” the bath, without interacting with the melt. As a result, the following effects occur: displacement of the blasting flame deep into the bath from the tuyere wall; the increase in the volume of Area 3 (Fig. 6); reducing the rate of circulation of the melt along the wall; killing the bath and removal of the high-temperature focus from the surface of the refractory.

Taking into account the equality of air and natural gas velocities, at a distance of 1–4 diameters from the tuyere cut [29, 33–34], the oxygen of the blasting does not enter into chemical interaction with the metals of the melt and, first of all, with metallic iron and sulfide. In addition, natural gas under the action of high temperature melt decomposes by the reaction proceeding with the absorption of heat. During the decomposition of natural gas blown into the melt through the tuyere, the temperature at the tuyere cut does not exceed 500 °C [5]. This circumstance protects the tuyere from the effects of high temperature of the melt and prevents burnout of the tuyere tube and the formation of “holes” in the refractory lining.

Going back away from the cut of the tuyere, the protective shell of natural gas is destroyed and the oxygen of the air actively interacts with the mass of the melt and natural gas. In this case, part of the oxygen is consumed

to oxidize the decomposition products of natural gas, reducing the concentration of free oxygen. Under these conditions, the oxidation rate of metals decreases and the exchange reactions between metals and mass sulfides and slag oxides gain an additional advantage due to a decrease in the partial pressure of oxygen [35–36].

The experience of using tuyres in a protective shell for blowing low energy parameters on 13 converters of Yuzhuralnickel concern makes it possible to give appropriate recommendations on their use and improvement of the conversion process:

- it is preferred to use TPS with a gap size of 1.5–2.5 mm;
- in the presence of sufficient amount of high pressure air, it is possible to reduce the diameter of the air pipe maintaining its throughput and self-cleaning mode;
- in the presence of oxygen and nitrogen for TPS it is possible to enrich air blasting with oxygen to the level of 60–80%, the limitation is determined only by the presence of a sufficient amount of cold additives for smelting in the converter and their autogenicity;
- it is possible to use as a protective environment both high-pressure air and nitrogen with natural gas, and air-vapor-oil mixture;
- in the calculation the design of the TPS it is recommended to take the speed of expiration of the blasting in the melt not lower than 180 m/s, the tuyre operates in self-cleaning mode at a speed of 230–250 m/s and its construction may be simplified by refusing to clean it;
- for the tuyre design “Yuzhuralnickel” with providing the speed of the air blasting in a protective shell of nitrogen on the level of not lower than 240 m/s it is recommended to apply the outer tube with outer diameter of 60 mm and the wall thickness of 4 mm, the inner tube with outer diameter of 48 mm and the wall thickness of 4 mm, that could require the application of pressure in the air tuyre collector not lower than 0.1 MPa and nitrogen pressure in nitrogen collector – 0,28 MPa. Air consumption per tuyre will be 25,6 m<sup>3</sup>/min, nitrogen – 6,2 m<sup>3</sup>/min.

## References

1. Zakharov B. N., Vorobev V. A. Blast smelting of oxidized nickel ores and converting of nickel mattes. Moscow : Metallurgiya, 1974. 168 p.
2. Pimenov L. I., Mikhaylov V. I. Processing of oxidized nickel ores. Moscow : Metallurgiya, 1972. 336 p.
3. Smirnov V. I., Tseydler A. A., Khudyakov I. F., Tikhonov A. I. Metallurgy of copper, nickel and cobalt. Vol. 2. Moscow : Metallurgiya, 1966. 406 p.
4. Shalygin L. M. About the ways of the converter conversion improving in nickel production. Ways to improve nickel production on the base of the new technique and technology application. Moscow : TsNIIN TsM, 1965. 208 p.
5. Arsentev P. P., Kvitko M. P. Converter process with bottom blast. Moscow : Metallurgiya, 1983. 128 p.
6. Features of converters with bottom blowing-down. Ferrous and non-ferrous metallurgy. Available at : <https://metallurgy.zp.ua/osobennosti-raboty-konverterovs-donnoj-produvkoj/>

7. Steel refining. Metal — information articles. Available at : <http://mitalolom.ru/2012/04/15/rafinirovaniya-stali/>
8. Conversion processes with combined blowing-down. Helpiks.org — Online Assistant. Available at : <http://helpiks.org/3-94360.html>
9. Converter processes with bottom oxygen blow. Metallurgy. Available at : <http://metallurgiya.net/metallurgiyastali/139-konvertiernye-processy-s-donnojproduvkoj-10.kislorodom.html>
10. Baptizmanskiy V. I. Mechanism and kinetics of processes in converter bath. Moscow : Metallurgizdat, 1960. 284 p.
11. Converter processes with bottom oxygen blow. Industry. Business directory. Available at : <http://buymore.pro/article/metally-i-metalloprokat/475/konvertiernyeprocessy-donnojproduvkoj-kislorodom>
12. Basic Oxygen Furnace: Equipment. Heat Treat Technologies. Energy Solutions Center. Available at : <http://heattreat-consortium.com/metals-advisor/basicoxygen-furnace/basicoxygen-furnace-equipment/>
13. Kudrin V. A. The oxygen using in steelmaking. Proceedings of the Moscow Institute of Steel and Alloys. Moscow : Metallurgizdat, 1957. pp. 214–232.
14. Bardin I. P., Afanasev S. G., Shumov M. M., Epshteyn Z. D. Application of oxygen in converter steelmaking. Moscow : Metallurgizdat, 1959. 264 p.
15. Mozgovoy N. I., Afanasev S. G., Shumov M. M. et al. Converting of high-phosphorous cast irons. *Proceedings of Central Research Institute of Ferrous Metallurgy*. Moscow : Metallurgizdat, 1956. Issue. 16. pp. 229–230.
16. Kapusta J., Lee R. G. H. The Savard-Lee shrouded injector: a review of its adoption and adaptation from ferrous to non-ferrous metallurgy. *Copper 2013 : proceedings of international conference*. Santiago, 2013. Vol. III (Book 2). pp. 1115–1151.
17. Bustos A. A., Kapusta J. P. High Oxygen Shrouded Injection in Copper and Nickel Converters. *The Brimacombe Memorial Symposium : proceedings*. Montreal : The Metallurgical Society of CIM, 2000. pp. 107–124.
18. Bustos A. A., Cardoen M., Janssens B. High oxygen enrichment at UM-Hoboken converters. *Copper 95 – Cobre 95 : proceedings of international conference. Vol. IV. Pyrometallurgy of Copper*. Montreal : The Metallurgical Society of CIM, 1995. pp. 255–269.
19. Bustos A. A., Kapusta J. P., Macnamara B. R., Coffin M. R. High Oxygen shrouded injection at Falconbridge. *Copper 99 – Cobre 99 : proceedings of international conference. Vol. VI. Smelting, Technology Development, Process Modeling and Fundamentals*. Warrendale : The Minerals, Metals and Materials Society of AIME, 1999. pp. 93–107.
20. Kapusta J. P., Stickling H., Tai W. High Oxygen Shrouded Injection at Falconbridge: Five Years of Operation. Converter and Fire Refining Practices. Warrendale : The Minerals, Metals and Materials Society of AIME, 2005. pp. 47–60.
21. Salt B., Cerilli E. Evolution of the Converter Aisle at Xstrata Nickel's Sudbury Smelter. *The International Peirce-Smith Converting Centennial Symposium : proceedings*. Warrendale : TMS, 2009. pp. 135–149.
22. Salt B., Cerilli E. Converter aisle improvements at Xstrata Nickel's Sudbury smelter. *The Pyrometallurgy of Nickel and Cobalt Symposium : proceedings of the 48<sup>th</sup> conference of metallurgists*. Montreal : The Metallurgical Society of CIM, 2009. pp. 333–349.
23. <http://www.copper2016.jp/program/html/session-04.html>
24. Kaixi Jiang, Lan Li, Yaping Feng, Haibei Wang, Bang Wei. The Development of China's Primary Copper Smelting Technologies. T. T. *Chen Honorary Symposium on Hydrometallurgy, Electrometallurgy and Materials Characterization : proceedings*. Warrendale : The Minerals, Metals and Materials Society of AIME, 2012. pp. 167–176.
25. Baojun Zhao, Zhixiang Cui, Zhi Wang. A New Copper Smelting Technology — Bottom Blown Oxygen Furnace Developed at Dongying Fangyuan Nonferrous Metals. *The Fourth International Symposium on High-Temperature Metallurgical Processing : proceedings*. Warrendale : The Minerals, Metals and Materials Society of AIME, 2013. pp. 3–10.
26. Kapusta J., Valencia N. C. et al. Energy Consumption in Copper Smelting: A new Asian Horse in the Race. *JOM: The journal of the Minerals, Metals & Materials Society*. 2015. Vol. 67, Iss. 5. pp. 1066–1074.
27. Tsemekhman L. Sh., Ezhov E. I., Pevzner M. I. et al. Autogenous smelting of sulphide copper-nickel ores with the use of oxygen-enriched blast immersed into the melt. *Pyrometallurgical processes in the nickel and cobalt engineering : proceedings*. Leningrad : Gipronikel, 1978. Iss. 8. pp. 21–24.
28. Nedvetskiy E. P., Khomchenkov B. M., Arefiev K. M., Tsemekhman L. Sh. Some regularities of operation of the oxygen tuyeres with protective nitrogen coating. *New directions in the nickel pyrometallurgy : proceedings*. Leningrad : Gipronikel, 1980. Iss. 8 (72). pp. 49–56.
29. Korol Yu. A., Naboychenko S. S., Gulyaev S. V. Use of natural gas in tuyeres with protective coating. *Tsvetnye Metally*. 2018. No. 7. pp. 46–50. DOI: 10.17580/tsm.2018.07.07
30. Korol Yu. A., Naboychenko S. S. Calculation of a lance in a protective shell for the conversion of nickel and copper matte and recommendations for its application. *Tsvetnye Metally*. 2018. No. 5. pp. 23–32. DOI: 10.17580/tsm.2018.05.04
31. Galnbek A. A., Barsukov N. M., Rusakov M. R., Ezhov E. I., Nedvetskiy E. P. Features of the liquid purging by a tuyere with protective envelope. *Pyrometallurgical processes in the nickel and cobalt engineering : proceedings*. Leningrad : Gipronikel, 1987. pp. 57–62.
32. Barsukov N. M., Korol Yu. A., Rusakov M. R., Galnbek A. A., Pashkovskiy A. A., Pronin A. F. Processing of nickel matte in horizontal converters with tuyeres in the containment. *Tsvetnye Metally*. 1992. No. 3. pp. 12–13.
33. Korol Yu. A., Naboychenko S. S. Improvement of the method of depletion of converter slags by the phase mixing method. *Tsvetnye Metally*. 2018. No. 8. pp. 37–44. DOI: 10.17580/tsm.2018.08.04
34. Korol Yu. A., Naboychenko S. S., Gulyaev S. V. The practice of using tuyeres in a protective layer in copper converting. *Tsvetnye Metally*. 2018. No. 6. pp. 14–20. DOI: 10.17580/tsm.2018.06.02
35. Reznik I. D., Ermakov G. P., Shneerson Ya. M. Nickel. Vol. 2. Moscow : Nauka i tekhnologii, 2001. 467 p.
36. Esin O. A., Geld P. V. Physical chemistry of pyrometallurgical processes. Part 1 : Reaction between gaseous and solid phases. Sverdlovsk : Metallurgizdat, 1962. 672 p. NFM